

# Commuter 2 Bike Hitch Rack

MODEL HR2500

## Assembly and Installation instructions

WARNING! THIS PRODUCT IS **NOT** TO BE USED ON ANY TRAILER

**PLEASE FOLLOW THESE IMPORTANT POINTS:**

- DRIVE SLOWLY WHEN USING THE RACK ON BUMPY OR DIRT ROADS.
- CHECK THE RACK, BIKES AND STRAPS REGULARLY DURING USE.
- IF YOU HAVE ANY QUESTIONS OR INSTALLATION PROBLEMS, PLEASE SEE YOUR RETAILER OR CONTACT US AT 800- 747- 4085.

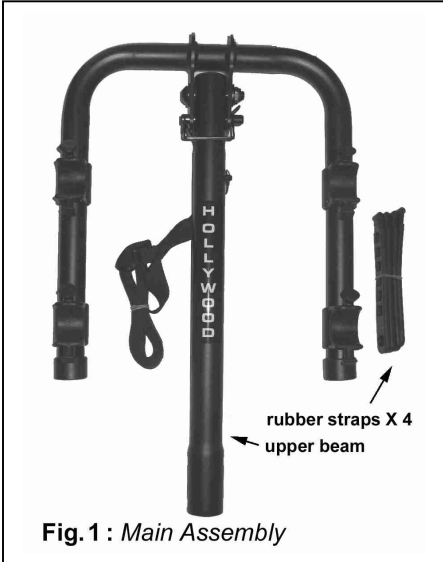

Commuter Rack box contents:

1. Main Assembly per Fig. 1
2. Lower Beam per Fig. 2
3. Receiver Tube per Fig. 3
4. Hardware bag per fig. 4, including
  - 4A: Threaded hitch pin bolt, washer, lock-washer and "R" clip
  - 4B: 1/2"-20 bolt, nut & washers for connection of lower beam to receiver tube.
  - 4C: Two 5/16"-18 carriage bolts, nuts & washers for connection of upper beam to lower beam.
  - 4D: Allen key for receiver tube adapter

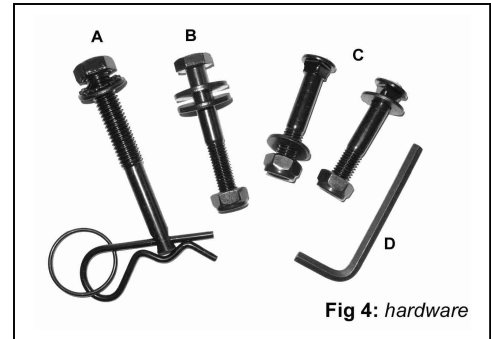

Tools required: two adjustable wrenches.

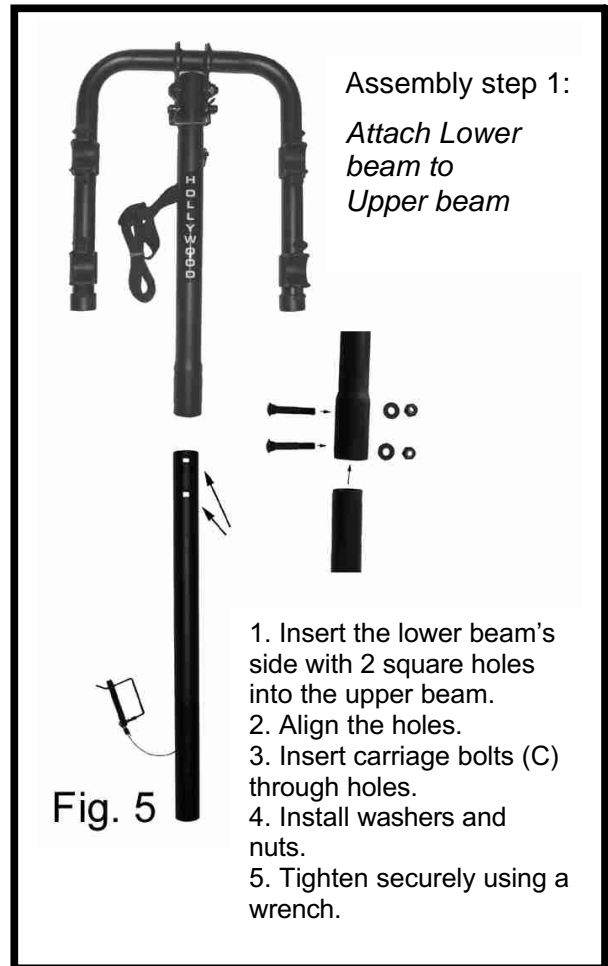
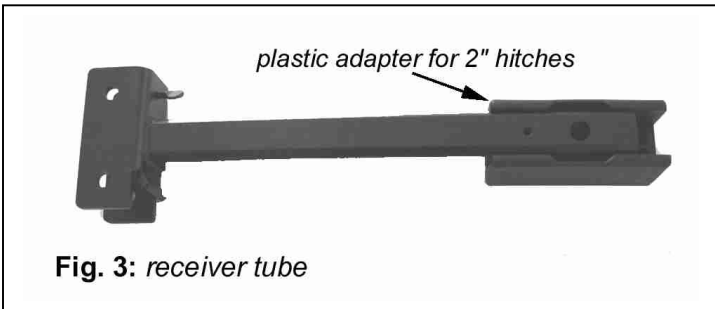
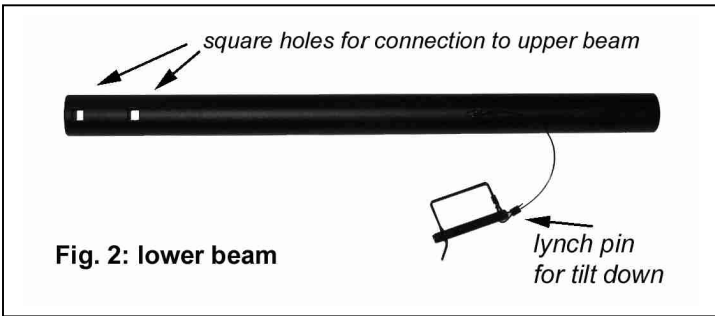

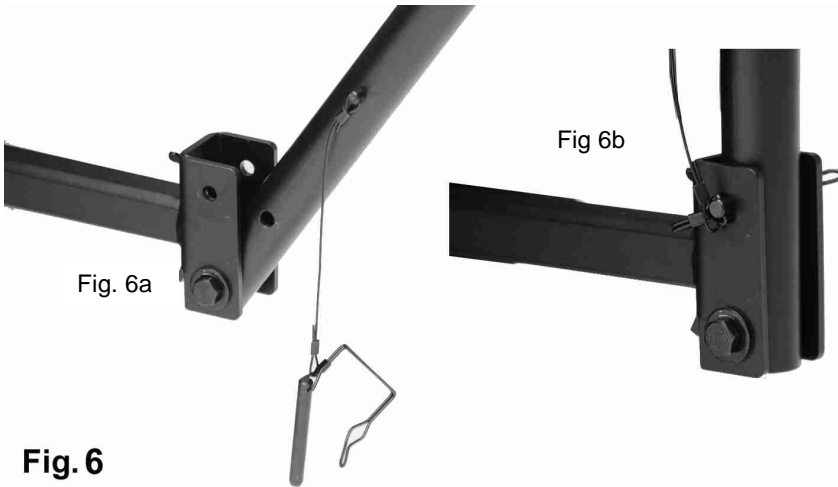

**Assembly step 2:**  
*Attach receiver tube*

1. Locate 1/2" bolt, washers and locknut (B).
2. Place a washer on the end of the bolt, and insert through the lower hole of the receiver tube's bracket and lower beam as shown in fig. 6a.
3. Attach other washer to bolt end, and install nut. Tighten nut onto bolt end using both wrenches.
4. Insert "lynch pin" through upper holes of bracket and tube, then fasten clasp on the pin per fig. 6b.

**Fig. 6**

**Installing into a 2" trailer hitch**

Place lock washer and flat washer onto hitch pin bolt as indicated. Insert the receiver tube into the hitch. Align the holes, insert the hitch pin bolt and tighten securely using a 3/4" wrench or equivalent.

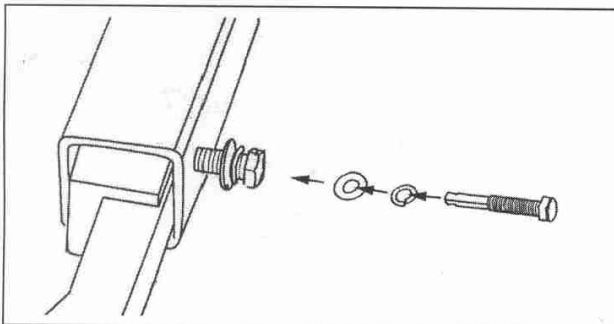

*Important! When inserting the hitch pin bolt, the bolt should pass through the receiver tube first then through the plastic spacer.*

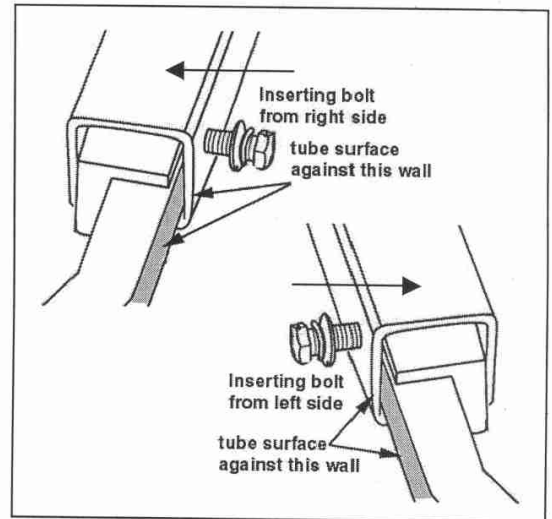

Install Hitch pin clip after tightening bolt

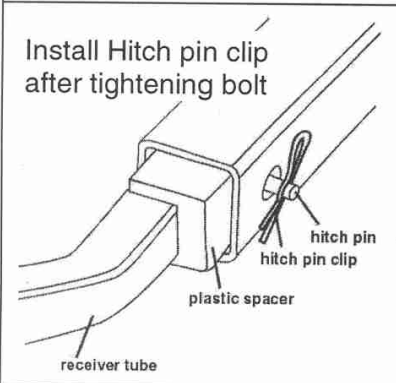

3/4" or equivalent

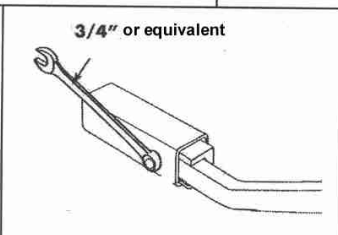

**Installing into a 1 1/4" trailer**

**Note:** The receiver tube comes ready for installation into a 2" hitch. If you have a 1 1/4" hitch, remove the plastic spacer as shown using 4mm allen key. Place lock washer and flat washer onto hitch pin bolt as indicated. Insert the receiver tube into the hitch. Align the holes, insert the hitch pin bolt and tighten securely using a 3/4" wrench or equivalent.

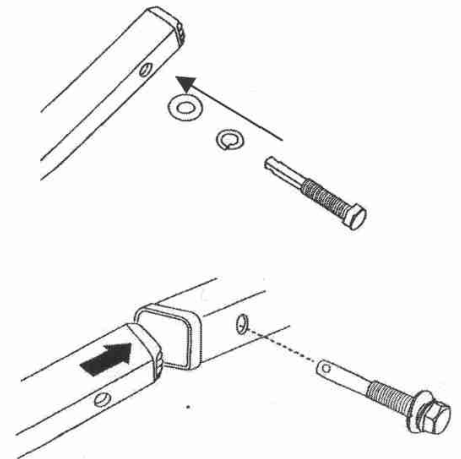
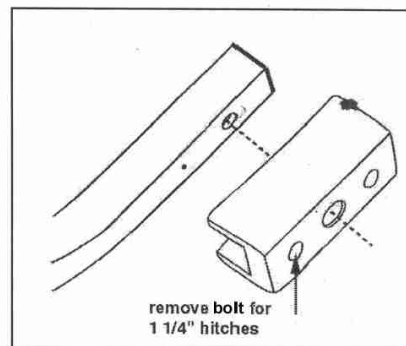

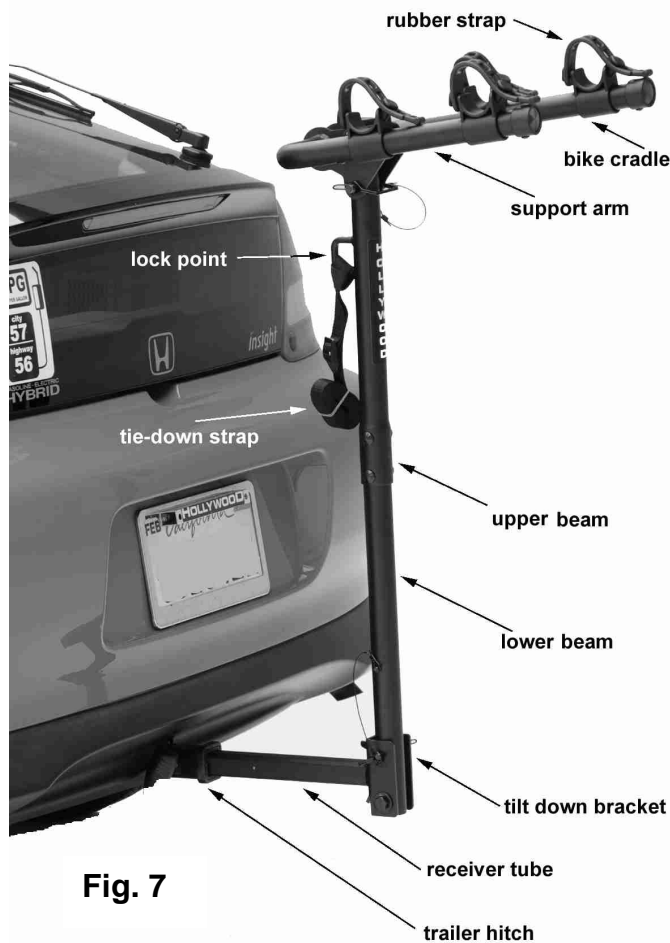

Fig. 7

**INSTALLING BIKES ON THE RACK:**

For ease of installation, we suggest you put the bigger bikes on the inside (closest to vehicle), smaller frames or kids bikes on the outside. The first bike loaded should have the handlebars facing towards the driver's side of the vehicle. Place the top tube (or closest appropriate frame tube) onto the bike cradles, install the straps over the bike tube and attach to the anchor tabs on both sides of the cradle. Use a strap notch-hole that provides a snug fit, but take care not to pull the strap over-tight. This can put undue stress on the bike's paint, and may over-stretch the strap, making it more susceptible to breakage.

After all the bikes have been installed, use the safety tie down strap (attached to the lock point in Fig. 7 and wrap it through the frames all of the bikes. Attach to the buckle then tighten securely. After all the bikes have been installed, use the safety tie down strap (attached to the lock point in Fig. 7 and wrap it through the frames all of the bikes. Attach to the buckle then tighten securely.



**Support Arms**

Rotate the support arm and align the plate holes with the tube holes per Fig. 8a. Insert pin and close safety clasp over pin end. To return the support arm to it's folded position, undo the safety clasp, then hold the arm with one hand and remove the pin so the arm doesn't drop quickly). Re-insert the pin per Fig. 8b.

Fig. 8a "in use position"

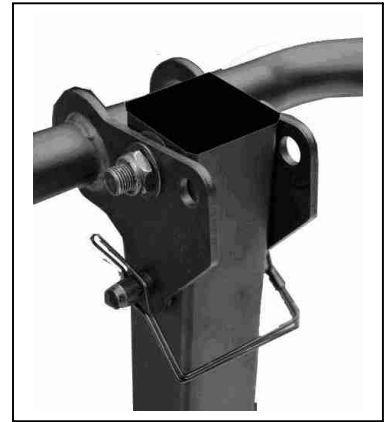

Fig. 8b "folded position"



*To tilt rack for access to rear of vehicle, remove lynch pin clip and gently lower the rack down.*

## REMOVING THE BIKES AND RACK

To remove the bikes, simply undo the straps and gently lift the bikes off. If you're in a parking lot, be sure to fold down the support arms so as to minimize the length of the rack when not in use. To remove the rack from the vehicle, remove the threaded hitch pin and slide the rack out of the hitch receiver.

## BACKING OUT OF DRIVEWAYS AND GOING OVER BUMPS

Please keep in mind that when transporting bikes, you will be carrying more weight on your hitch. This means the rear of your vehicle will be lower to the ground. When going up driveways or over bumps, drive slowly and at an angle if possible. If you have a car or minivan where the hitch is low to the ground, the rack may hit the ground.



### Optional Accessories (sold separately):

**LHPTC:** Threaded locking hitch pin with 8' security cable, keyed alike.

**BBR:** Artificial top tube adapter for some ladies bikes and bikes with non-standard frame designs.



LHPTC



BBR

### Limited Lifetime Warranty

Hollywood Racks will warrant its car racks and accessories during the time that an original retail purchaser owns the product subject to the exclusions and limitations of this warranty. Hollywood Racks will remedy defects in materials and workmanship by repairing or replacing (at its option) a defective part or the complete rack without charge for labor or parts. Hollywood Racks may elect (at its option) to issue a refund equal to the purchase price paid for the product.

This warranty does not cover problems caused by normal wear and tear including (but not limited to) weather, scratches, dents, rust, accidents, unlawful vehicle operation, misuse, abuse, neglect, theft, unauthorized modifications, or unauthorized repair. No warranty is given for defects resulting in incorrect assembly, incorrect installation onto the vehicle, installation on a "no fit" vehicle, incorrect attachment of bicycles onto the rack, or overloading of the rack's weight restrictions. This warranty terminates if the original retail purchaser transfers the product to any other person.

If a product is believed to be defective, the original retail purchaser should contact either the original retailer or Hollywood Racks directly at 800-747-4085 or at [info@hollywoodracks.com](mailto:info@hollywoodracks.com)

**Disclaimer of Liability:** Repair or replacement of a defective product or the issuance of a refund or credit (as determined by Hollywood Racks) is a purchaser's exclusive remedy under this warranty. Damage to a purchaser's vehicle, cargo, bicycles and or to any other person is excluded. This warranty is expressly made in lieu of any and all other express warranties, whether oral or written.

Hollywood Racks shall not be liable for any direct, indirect, consequential, incidental, special, punitive or any other damages in connection with the purchase, use or handling of this product.

Some states do not allow the exclusion or limitation of consequential or incidental damages and the above limitation may not apply to you. This warranty gives you specific legal rights and you have other rights, which vary from state to state.

**Hollywood Racks**  
12812 S. Spring St. Los Angeles, CA 90061  
(800) 747-4085 or (310) 516-8600 FAX (310) 516-8955  
[www.hollywoodracks.com](http://www.hollywoodracks.com)  
[info@hollywoodracks.com](mailto:info@hollywoodracks.com)  
Customer Service: M-F 8:00 AM – 3:00 PM PST  
Made in Taiwan 12/08 version A